



Plain Township

**Board of Trustees Regular Meeting Agenda
June 6, 2018 - 7:00 p.m. at the Fire Station**

1. Pledge of Allegiance
2. Roll Call
3. Additions or Corrections to Agenda
4. Approval of Minutes – May 2, 2018
5. Approval of Minutes – May 16, 2018
6. Pending Warrants
7. Departments

Administrator

Resolution 180606A1 – A resolution to pay Columbus Pool Management

Report

Zoning

Report

Resolution 180606Z1 – A resolution to declare a nuisance at 6143 Alice Drive

Added Resolution 180606Z2 - A resolution to declare a nuisance at 7650 Morse Rd.

Road/Maintenance Department

Report

Fire Department

Report

EMS & Fire Runs

Ladder Committee Update

Update on Firefighter vacancy

Added Resolution 180606F2 - A resolution to Pay Ohio Health Lifelink
Resolution 180606F3 - A resolution to Pay Physio Control

City Liaison

Plain Local School District Liaison – (Phil Darrow)

Township Fiscal Officer

Trustees

Dave Ferguson
Dave Olmstead
Thomas Rybski

6. **Old Business**
7. **New Business**
8. **Citizen's Comments**
9. ***Executive Session – if requested**
10. **Adjournment**
11. **Sign Documents**

Agenda is subject to amendment by the Board at the time of meeting.

Executive Session: Pursuant to Ohio Revised Code 121.22(G)(1) for appointment, employment, promotion or compensation, discipline demotion or dismissal, **or*

*Pursuant to ORC 121.22 (G)(2) to consider purchase of property for public purposes or sale of property at competitive bidding, **or***

Pursuant to ORC 121.22(G)(3) Conference with attorney for public body to discuss pending or imminent court action.

RECORD OF PROCEEDINGS

Minutes of Meeting

Plain Township Board of Trustee Meeting

Held

Fire Station

7:00 p.m.

The Plain Township Board of Trustees met in regular session at the Plain Township Fire Station, 9500 Johnstown Road, New Albany, Ohio.

Mr. Olmstead called the meeting to order with the Pledge of Allegiance to the flag.

Roll Call: Members Present Dave Olmstead and Tom Rybski. Dave Ferguson was absent. Bud Zappitelli, Fiscal Officer, was present. Other people present were Chief Hoovler, Ben Collins and Cindy Powell.

Visitors present: Debra Lowery and Bart Anderson

ADDITIONS OR CORRECTIONS TO THE AGENDA

Chief Hoovler tabled Resolution 180606F1. Chief Hoovler added Resolution 180606F2 and 180606F3. Mr. Collins added Resolution 180606Z2.

APPROVAL OF MINUTES

Mr. Rybski made a motion to approve the May 3, 2018 Board of Trustees Meeting minutes as submitted. Mr. Olmstead seconded the motion.

Vote: All Aye (Resolution 18060601)

Mr. Rybski made a motion to approve the May 16, 2018 Board of Trustees Meeting minutes as submitted. Mr. Olmstead seconded the motion.

Vote: All Aye (Resolution 18060602)

PAYMENT OF THE BILLS

Mr. Olmstead made a motion to pay the pending warrants in the amount of \$324,852.38.

Mr. Rybski seconded the motion. Vote: All Aye (Resolution 18060603)

ADMINISTRATOR

Mr. Olmstead asked if there was a great weekend at the pool. Mr. Collins said that it was a great opening. They had great weather. They have done really well with the receipts since they opened so far it is \$50,000 to date. He said today we delayed opening because of the cool weather then people came out and enjoyed the sunshine. Mr. Rybski asked if we post that it will be a delayed opening. Mr. Collins said yes, on social media.

There was a brief discussion concerning the Spectrum internet install date at the pool.

Mr. Collins said they are meeting with the SWACO Consortium members to talk about options. There was discussion about SWACO contract options and rates.

Mr. Olmstead asked Chief Hoovler to provide the total estimated cost of the new ladder truck including anything we are going to do like signage. In the past, after equipment has gotten here, we have added radios and such. There was discussion concerning things that are included in the purchase.

Mr. Olmstead made a motion to pass Resolution No. 180606A1. Be it resolved, to set aside and pay Columbus Pool Management, Inc., 8852 Whitney Dr., Lewis Center, OH 43035, \$51,620.00 to cover the July contract payment from fund 14-A-07 (Pool – Contracts).

Remit to:

Columbus Pool Management, Inc.

4495 Keheley Drive

Marietta, GA 30066

Mr. Rybski seconded the motion. Vote: All Aye

ZONING

Mr. Collins said that he had two nuisance resolutions. He said that Oakland Nursery submitted an application for a modification to their site plan. The owner is scheduled to meet with the adjacent property owner concerning screening and they will submit their application with a site screening plan.

Mr. Rybski asked if everyone accepted their appointment to the zoning boards. Mr. Collins said so far. He said there will be meetings for both groups next week. Mr. Olmstead asked if there will be an orientation for them like we have done previously. Mr. Collins said they will have three new members on the Zoning Commission so especially for that group we would like to bring in our legal counsel to run through the process. He said that he will schedule something. Mr. Rybski said that he would like to attend the trainings.

Mr. Olmstead asked about 11407 Johnstown Road. Mr. Collins said that we had a nuisance resolution on this property last month. He said there was a crew at the site for two weeks and they reposted the property. There was a brief discussion concerning the property improvements.

Mr. Collins said that the owner at 10670 Johnstown Road is still interested in rezoning his property for a specific limited use. Mr. Collins said that he requested that the resident removal the commercial vehicles. There was discussion concerning living in the RV being prohibited by the Zoning Resolution, getting the commercial vehicles off the site, screening the property and discussions with the Prosecuting Attorney.

There was a brief discussion concerning some upcoming zoning cases.

Mr. Rybski made a motion to pass Resolution No. 180606Z1. WHEREAS the overgrown weeds and vegetation located at Plain Township Parcel Number 220-001545 and located at 6143 Alice Drive, Westerville, Ohio 43081 constitute a nuisance that is present and ongoing;

THEREFOR BE IT RESOLVED that the Plain Township Board of Trustees hereby orders the legal owner Gregory Morris, of 6143 Alice Drive, to abate, control, or remove said overgrown weeds and vegetation that are a present and ongoing nuisance;

BE IT FURTHER RESOLVED that if said overgrown weeds and vegetation are not abated, controlled, or removed, or if provision for its abatement, control or removal is not made within four (4) days, the Plain Township Board of Trustees shall provide for the abatement, control or removal of said nuisance;

BE IT FURTHER RESOLVED that any expenses incurred by the Plain Township Board of Trustees in providing for the abatement, control, or removal of said nuisance shall be paid out of the township general fund from moneys not otherwise appropriated;

BE IT FURTHER RESOLVED that the Plain Township Board of Trustees shall make a written report to the county auditor identifying the premises and all expenses incurred in providing for the abatement, control, or removal of said nuisance. Any expenses incurred shall be entered upon the tax duplicate and become a lien upon the land from the date of entry. Mr. Olmstead seconded the motion. Vote: All Aye

Mr. Olmstead made a motion to pass Resolution No. 180606Z2. WHEREAS Plain Township Parcel Number 220-001012 located at 7650 Morse Road, New Albany, Ohio 43054 is a developed lot with an existing home and the overgrown weeds and vegetation located at 7650 Morse Road constitute a nuisance that is present and ongoing;

THEREFOR BE IT RESOLVED that the Plain Township Board of Trustees hereby orders the documented owner Mahendra Prasanna, of 1293 Terrace Park Drive, Columbus, Ohio 43235, to abate, control, or remove said overgrown weeds and vegetation that are a present and ongoing nuisance and to maintain the yard in a neat and orderly state;

BE IT FURTHER RESOLVED that if said overgrown weeds and vegetation are not abated, controlled, or removed, or if provision for its abatement, control or removal is not made within seven (7) days, the Plain Township Board of Trustees shall provide for the abatement, control or removal of said nuisance;

BE IT FURTHER RESOLVED that any expenses incurred by the Plain Township Board of Trustees in providing for the abatement, control, or removal of said nuisance shall be paid out of the township general fund from moneys not otherwise appropriated;

BE IT FURTHER RESOLVED that the Plain Township Board of Trustees shall make a written report to the county auditor identifying the premises and all expenses incurred in providing for the abatement, control, or removal of said nuisance. Any expenses incurred shall be entered upon the tax duplicate and become a lien upon the land from the date of entry. Mr. Rybski seconded the motion. Vote: All No

There was discussion after the motion was made concerning specifics of what was considered the yard area in the resolution. The resolution failed as it was originally introduced.

Mr. Olmstead made a motion to pass Resolution No. 180606Z2 as amended. WHEREAS Plain Township Parcel Number 220-001012 located at 7650 Morse Road, New Albany, Ohio 43054 is a developed lot with an existing home and the overgrown weeds and vegetation located at 7650 Morse Road constitute a nuisance that is present and ongoing; THEREFOR BE IT RESOLVED that the Plain Township Board of Trustees hereby orders the documented owner Mahendra Prasanna, of 1293 Terrace Park Drive, Columbus, Ohio 43235, to abate, control, or remove said overgrown weeds and vegetation that are a present and ongoing nuisance and to maintain the yard in a neat and orderly state; from the rear of the structure to Morse Road

BE IT FURTHER RESOLVED that if said overgrown weeds and vegetation are not abated, controlled, or removed, or if provision for its abatement, control or removal is not made within seven (7) days, the Plain Township Board of Trustees shall provide for the abatement, control or removal of said nuisance;

BE IT FURTHER RESOLVED that any expenses incurred by the Plain Township Board of Trustees in providing for the abatement, control, or removal of said nuisance shall be paid out of the township general fund from moneys not otherwise appropriated;

BE IT FURTHER RESOLVED that the Plain Township Board of Trustees shall make a written report to the county auditor identifying the premises and all expenses incurred in providing for the abatement, control, or removal of said nuisance. Any expenses incurred shall be entered upon the tax duplicate and become a lien upon the land from the date of entry. Mr. Rybski seconded the motion. Vote: All Aye

MAINTENANCE

There was a brief discussion concerning Maintenance Department staffing and coverage.

Mr. Collins said there was a contract for a company to paint at the pool. He said because of all the rain this year the contractor was backed up and they had to cancel our work. Mr. Pharris worked with Maintenance staff and summer help to get everything prepped and painted to freshen up the pool. Mr. Rybski wanted to pass their thanks on to the staff.

There was discussion concerning a pay increase for Michael Bullard.

FIRE DEPARTMENT

Chief Hoovler said there have been 157 runs since the last Board of Trustees meeting.

Chief Hoovler wanted to congratulate Paul DuBeck who graduated at Columbus State with an Associate Degree in Fire Science. He said that Battalion Chief Brown is back to work light duty.

There was discussion concerning the firefighter hiring process and schedule.

**Mr. Olmstead made a motion to pass Resolution No. 180606F2. Be it resolved to pay Ohio Health Lifelink \$3400.00 for a PHTLS Class out of fund 28-A-05C EMS (Other-Training). \$3275 will be covered by the EMS grant money.
Mr. Rybski seconded the motion. Vote: All Aye**

**Mr. Rybski made a motion to pass Resolution No. 180606F3. Be it resolved to pay Physio Control \$2,930.76 for annual maintenance out of fund 28-A-05F EMS (Routine Repair).
Mr. Olmstead seconded the motion. Vote: All Aye**

FISCAL OFFICE

There was discussion concerning the 2019 Tax Budget and deadlines.

OLD BUSINESS

Mr. Rybski said that Mr. Collins was continuing to work with the Franklin County Engineers office concerning the repairs to the Bevelhymer Road ditch and we are trying to get a resolution. There was a brief discussion concerning the repair and possible costs.

RECOGNITION OF VISITORS/ CITIZEN COMMENTS

Bart Anderson – 3925 Pine Meadow Road – Mr. Anderson said that he has a drainage issue that he is trying to get resolved on Pine Meadow Road. There was discussion concerning a possible cause for the issue. Mr. Collins will work with Mr. Anderson to see how the Township can help him resolve the issue.

ADJOURNMENT

Mr. Olmstead made a motion to adjourn the meeting at 7:48 p.m. Mr. Rybski seconded the motion. Vote: All Aye

BOARD OF TRUSTEES:

David Ferguson, Trustee



Dave Olmstead, Trustee



Thomas Rybski, Trustee



Bud Zappitelli, Fiscal Officer

Warrant Number	Warrant Amount	Voucher Number	Payee	Purpose
601	178.76	VW 601	AUTOMATIC DATA PROCESSING, INC.	ADP PAYROLL SERVICES FOR 05/18/2016
57776	990.51	VW57776	ACUITY SPECIALTY PRODUCTS, INC.	FIRE ZEP SUPPLIES SHINE/LUBRICANT JH CP
57777	494.17	VW57777	AT&T	GEN/FIRE/ROADS MONTHLY PHONES CP
57778	2197.91	VW57778	AMERICAN ELECTRIC POWER	GEN/FIRE/ROADS MONTHLY ELEC SERV BC CP
57779	1479.73	VW57779	ARROW INTERNATIONAL, INC.	EMS MEDICAL SUPPLIES NEEDLES JH CP
57780	798.06	VW57780	BUCKEYE POWER SALES CO., INC.	GEN/CEM/FIRE/RDA/PL GEN RENTAL FIL BC CP
57781	816.02	VW57781	BROSIUS, JOHNSON AND GRIGGS	GEN PROF SERV RENDERED MISC & ZONE BC CP
57782	1946.70	VW57782	COLUMBUS CITY TREASURER	FIRE 1ST QRT RADIO CHARGES JH CP
57783	269.50	VW57783	CHARDSNYDER	GEN/FIRE/ROADS MAY 2018 ADMIN FEE CP
57784	1600.00	VW57784	COLUMBUS-CITY TREASURER	GEN/FIRE/ROADS QRT/MTH WATER SERV BC CP
57785	125.35	VW57785	BEN COLLINS	GEN - REIMBURSE MAY -ZONE/ADMIN CP
57786	846.00	VW57786	COLUMBUS POOL MANAGEMENT, INC	POOL RESCUE TUBES/LIFE GUARDES BC CP
57787	121.15	VW57787	COLUMBUS SUPPLY	FIRE FIRE HOOKS JH CP
57788	235.00	VW57788	CORVUS JANITORIAL SYSTEMS	GEN TOWNHALL CLEANING JUNE 2018 BC CP
57789	52.40	VW57789	CRYSTAL SPRINGS	GEN WATER SERVICE TOWNSHIP BC CP
57790	1385.46	VW57790	FIFTH THIRD BANK	GEN/CEM/ROADS/POOL MISC SUPPLIES BC CP
57791	1786.98	VW57791	FIFTH THIRD BANK	FIRE/EMS MISC SUPPLIES JH CP
57792	188.00	VW57792	D & L PLUMBING INC.	POOL BACKFLOW CERTIFICATIONS BC CP
57793	1642.42	VW57793	DAYTON MAILING SERVICES INC	GEN NEWSLETTER PROCESSING/POSTAGE BC CP
57794	9.27	VW57794	DIANE LEWIS	GEN TRAVEL REIMBURSEMENT CP
57795	1392.08	VW57795	W.S. DARLEY & CO.	FIRE PART - RUGGED RANDY /FREIGHT JH CP
57796	2641.34	VW57796	MANSFIELD OIL COMPANY	GAS/FIRE SULFUR/OCTANE BC JH CP
57797	425.00	VW57797	1ST RESPONSE PEST MANAGEMENT, LLC	POOL PEST CONTROL BC CP
57798	12007.69	VW57798	FLORA'S DIESEL REPAIR SERVICE INC.	FIRE L-121 REPAIRS/INSPECTIONS JH CP
57799	345.00	VW57799	FRANKLIN COUNTY TOWNSHIP ASSOCIATION	GEN/ROADS MEMBERSHIP DUES 2018-19 BC CP
57800	134.68	VW57800	GFC LEASING OH	GEN COPIER LEASE PAYMENT TWP BC CP
57801	45.00	VW57801	GEIGER EXCAVATION INC	CEM TOPSOIL BC CP
57802	85.31	VW57802	GORDON FLESCH CO., INC.	GEN COPIER USAGE BC CP
57803	587.65	VW57803	GREAT IMPRESSIONS SIGNS & DESIGNS, INC.	POOL SIGNS BC CP
57804	81.25	VW57804	GRAINGER	POOL TAP/TAPER BC CP
57805	13.41	VW57805	SALLY HATFIELD	GEN TRAVEL REIMBURSEMENT CP
57806	144.95	VW57806	IJS OF COLUMBUS	ROADS BATTERY REPAIRS 11 BC CP
57807	124.95	VW57807	INTERSTATE	CEM/ROADS BATTERY BC CP
57808	214.62	VW57808	JOSEPH HERREN	FIRE TRAVEL REIMBURSEMENT JH CP
57809	77.97	VW57809	KURTZ BROS., CENTRAL OHIO, LLC	CEM GROWERS BLEND GRASS SEED BC CP
57810	709.98	VW57810	MICRO CENTER A/R	FIRE APPLE MAC/SOLAR KEYBOARD JH CP
57811	110.39	VW57811	NEW ALBANY ACE HARDWARE	FIRE/POOL MISC PARTS/FASTNERS JH BC CP
57812	15.75	VW57812	NEXTEL COMMUNICATIONS	EMS LIFE PACK MODEMS CP
57813	6790.00	VW57813	OHIO PUBLIC EMPLOYEES DEFERRED COMP PROG	GEN/FIRE/ROADS DEFERRED COMP 5/25/18 CP
57814	7965.00	VW57814	OHIO PUBLIC EMPLOYEES DEFERRED COMP PROG	GEN/FIRE/ROADS DEFERRED COMP 6/8/18 CP
57815	1887.00	VW57815	OHIO HEALTH/WORKHEALTH	FIRE APRIL 2018 SCREENINGS JH CP
57816	519.90	VW57816	OHIO POWER TOOL	FIRE FLOOD LIGHTS/BATTERY PACK JH CP
57817	399.00	VW57817	PATTERSON POOLS, LLC	POOL GRATE AND CLIPS BC CP
57818	2095.00	VW57818	PAUL CONWAY SHIELDS	FIRE REVEAL FIRE PRO/SNAP CLIP JH CP
57819	1760.82	VW57819	PAUL DUBECK	FIRE 2018 TUITION REIMBURSE CP
57820	165.86	VW57820	PHOENIX OUTFITTERS	FIRE SLIP ON OXFORDS JH CP
57821	2488.00	VW57821	JASON K PIPER	CEM CEM MARKER FOUNDATIONS 6/1/18 BC CP

PENDING WARRANT RI T
Plain Township (2018)

Date: 06/05/18

Warrant Number	Warrant Amount	Voucher Number	Payee	Purpose	
57822	200.00	VW57822	PORTA KLEEN	GEN FOUNDERS DAY - PORTA JOHN	BC CP
57823	70.00	VW57823	PROSIGN STUDIO	FIRE MAX METAL SIGNS	JH CP
57824	450.00	VW57824	PSEE SOLUTIONS	GEN/ROADS/POOL MONTHLY CONTRACT	CP
57825	575.34	VW57825	RECREONICS INC.	POOL EYE/SKIN FLUSH/UMBRELLA/STRAP	BC CP
57826	127.20	VW57826	RECREATION SUPPLY	POOL LADDER BUMPER	BC CP
57827	119.40	VW57827	SAFETY SERVICE PRODUCTS INC	FIRE FIRE LINE DO NOT CROSS	JH CP
57828	54.65	VW57828	THE SHERWIN-WILLIAMS CO	POOL BUCKET/BRUSHES/CONTRA PACK	BC CP
57829	24.47	VW57829	STAPLES BUSINESS ADVANTAGE	GEN MISC OFFICE SUPPLIES	BC CP
57830	54.00	VW57830	TERMINIX PROCESSING CENTER	CEM/ROADS MONTHLY PEST CONTROL	BC CP
57831	1409.00	VW57831	TRUGREEN PROCESSING CENTER	CEM LAWN SERVICE	BC CP
57832	91.51	VW57832	TRURO TOWNSHIP	FIRE SHARED SERVICE --TW TELCOM	JH CP
57833	177.44	VW57833	TYCO INTEGRATED SECURITY LLC	POOL SECURITY SERVICE	BC CP
57834	25442.00	VW57834	UNITED REFRIGERATION SERVICE, INC	FIRE 3 TRANE FURNACES	JH CP
57835	21.49	VW57835	THE WASSERTROM COMPANY	FIRE ALUM SCOOP	JH CP
57836	55.00	VW57836	ALESA WOODS	POOL RETURN OF SECURITY DEP	BC C
57837	255.77	VW57837	WEST COAST NETTING, INC.	POOL SUPPLIES- ROPE BOUND	BC CP
57838	275.00	VW57838	WOW BUSINESS SERVICES, LLC	FIRE JULY 2018 SERVICE	JH CP
57839	3000.00	VW57839	PRAETORIAN DIGITAL	EMS MEDIC & FIRE COURSES	JH CP
57840	100.81	VW57840	VERIZON WIRELESS	GEN/FIRE MONTHLY CELL CHARGES	CP
57841	872.18	VW57841	COLUMBIA GAS OF OHIO, INC.	GEN/FIRE/ROADS/POOL MONTHLY GAS	BC CP
93766.25		Total Amount of Pending Warrants			

Warrant Number	Warrant Amount	Voucher Number	Payee	Purpose	
514	6338.97	VW 514	CHARDSNYDER	FIRE HRA REIMBURSEMENT 5.14.18	
518	257.40	VW 518	AUTOMATIC DATA PROCESSING, INC.	ADP PROCESSING CHARGES 5/17/18	
519	208.48	VW 519	AUTOMATIC DATA PROCESSING, INC.	ADP PROCESSING FEES FOR 05/04/18	
520	1277.67	VW 520	CHARDSNYDER	HRA REIMBURSEMENT 5.21.18	
521	4674.35	VW 521	DELTA DENTAL	GEN/FIRE/ROADS DENTAL JUNE 2018	BC CP
522	939.75	VW 522	STANDARD INSURANCE COMPANY	GEN/FIRE/ROADS LIFE INS JUNE 2018	BC CP
523	64440.37	VW 523	UNITED HEALTHCARE	GEN/FIRE/ROADS HEALTHCARE JUNE 2018	CP
524	1057.88	VW 524	VISION SERVICE PLAN OHIO	GEN/FIRE/ROADS VISION JUNE 2018	BC CP
525	28771.99	VW 525	AUTOMATIC DATA PROCESSING, INC.	ADP PAYROLL TAXES 05/25/18 \$28771.99	
526	110121.92	VW 526	AUTOMATIC DATA PROCESSING, INC.	ADP PAYROLL DIRECT DEP/CHECKS 110121.92	
527	7164.92	VW 527	PUBLIC EMPLOYEES RETIREMENT SYSTEM	APRIL 2018 EMPLOYERS CONTRIBUTION	
528	5177.85	VW 528	PUBLIC EMPLOYEES RETIREMENT SYSTEM	EMPLOYEE SHARE APRIL 20185	
529	654.58	VW 529	CHARDSNYDER	FIRE HRA REIMBURSEMENT 5.28.18	CP
231086.13		Total Amount of Pending Warrants			

324,852.38 Grand Total

TRUSTEE

TRUSTEE

TRUSTEE

FISCAL OFFICER

ADMINISTRATOR'S REPORT

June 6, 2018



- 5/22 MORPC Northeast Governments meeting
- 5/22 OCMA Conference Committee call
- 5/22 Firefighter interviews
- 5/24 New Albany Water Main review with FD
- 5/24 Firefighter interviews
- 5/25 Review BWC claim with Careworks
- 5/29 Review pool trespassing with CPM
- 6/1 Review Ladder truck purchase with legal counsel
- 6/4 Submit Ladder truck specifications to county prosecutor

POOL

The pool had one of its best opening weekends ever, recording approximately \$23,000 in receipts Saturday through Monday. Spectrum has approved construction of a high speed internet 100 Mbps connection at the pool with an install date of June 21. In the interim, internet service provided by AT&T is being increased to 25 Mbps to allow the new VOIP phones to be utilized this season. I reviewed a situation with a family trespassing into the pool by not paying. The event has been documented by video and if the activity repeats, it will be reported to the police department.

HRA REIMBURSEMENTS

Year to date HRA reimbursements through May 31 total \$35,775. HRA reimbursements for the same time period in 2017 totaled \$23,394.58.

SWACO

The recycling processing bid came in from Rumpke. Recycling processing has always been a free service to SWACO consortium #1. We still have one year available to renew at that price. The new bid was \$35 a ton, which would equal an increase of \$1.37 a month if passed on by the collection haulers to the customer.

LADDER TRUCK

Attached are the schematic drawing, proposal and contract terms for the purchase of a new Sutphen Aerial Platform SPH-100 with Equipment Package and Communication Package. The 121 pages of specifications for the Sutphen ladder truck were forwarded to the county prosecutor for review as required by Ohio Revised Code 505.37. A resolution to authorize the purchase is being drafted by legal counsel and will be presented at the June 20 board meeting.

PLAIN TOWNSHIP BOARD OF TRUSTEES
FRANKLIN COUNTY, OHIO

RESOLUTION NO. 180606A1

A RESOLUTION TO AUTHORIZE PAYMENT TO COLUMBUS POOL
MANAGEMENT, INC. FOR 2018 POOL MANAGEMENT FEES

Be it resolved, to set aside and pay Columbus Pool Management, Inc., 8852 Whitney Dr., Lewis Center, OH 43035, \$51,620.00 to cover the July contract payment from fund 14-A-07 (Pool – Contracts).

Remit to:
Columbus Pool Management, Inc.
4495 Keheley Drive
Marietta, GA 30066

Adopted this 6th Day of June, 2018.



Bud Zappitelli, Fiscal Officer

David Ferguson, Trustee



Dave Olmstead, Trustee



Tom Rybski, Trustee

Payment Schedule:

1% deposit due upon acceptance of agreement \$2,065

9% due on or before April 1, 2018 \$18,583

15% due on or before May 1, 2018 \$30,972

25% due on or before June 1, 2018 \$51,620

25% due on or before July 1, 2018 \$51,620

20% due on or before August 1, 2018 \$41,296

5% due on or before September 30, 2018 \$10,324

Total: \$206,480

ZONING REPORT

June 6, 2018



11407 JOHNSTOWN ROAD

This property has been maintained. A crew was seen working at the property over two weeks. The property has been relisted as an investment opportunity taken down to the studs.

10670 JOHNSTOWN ROAD

I met the owner on the property to discuss the commercial vehicles. The owner advised that the box trailers were for personal use and has screened the commercial trailers from view. The dump truck has been removed from the property. The RV is stored according to the zoning resolution and the owner denies use as a dwelling. I was able to confirm the owner also owns a home in Indiana.

6143 ALICE DRIVE

After the notice to abate the declared nuisance was delivered, the property was mowed. However, the grass is in need of mowing again, and staff anticipates that the owner will not maintain the lawn without notice. A second nuisance resolution is being submitted.

5992 ALICE DRIVE

A complaint was received regarding 5992 Alice Drive. After contacting the owner, the nuisance was remedied.

8195 WALNUT STREET

A complaint was received regarding overgrown grass at 8195 Walnut Street. After contacting the owner, the grass was mowed.

BOARD OF ZONING APPEALS

The following items are scheduled for public hearing on June 12:

- A. Variance Application 05-08-2018-01 - 5180 Central College Road – Section 600.01 – Telecommunications Tower
- B. Variance Application 05-08-2018-02 5450 East Walnut Street – Section 406.02 – Accessory Structure
- C. Variance Application 05-08-2018-03 5600 East Walnut Street – Section 240.04.3 – Side Yard Setback

ZONING COMMISSION

I have still not received the plan modification application from Oakland Nursery to address the site changes and screening. The next meeting of the Zoning Commission is scheduled for June 14.

**PLAIN TOWNSHIP BOARD OF TRUSTEES
FRANKLIN COUNTY, OHIO**

RESOLUTION NO. 180606Z1

A RESOLUTION TO DECLARE A NUISANCE AND ORDER ABATEMENT

WHEREAS the overgrown weeds and vegetation located at Plain Township Parcel Number 220-001545 and located at 6143 Alice Drive, Westerville, Ohio 43081 constitute a nuisance that is present and ongoing;

THEREFOR BE IT RESOLVED that the Plain Township Board of Trustees hereby orders the legal owner Gregory Morris, of 6143 Alice Drive, to abate, control, or remove said overgrown weeds and vegetation that are a present and ongoing nuisance;

BE IT FURTHER RESOLVED that if said overgrown weeds and vegetation are not abated, controlled, or removed, or if provision for its abatement, control or removal is not made within four (4) days, the Plain Township Board of Trustees shall provide for the abatement, control or removal of said nuisance;

BE IT FURTHER RESOLVED that any expenses incurred by the Plain Township Board of Trustees in providing for the abatement, control, or removal of said nuisance shall be paid out of the township general fund from moneys not otherwise appropriated;

BE IT FURTHER RESOLVED that the Plain Township Board of Trustees shall make a written report to the county auditor identifying the premises and all expenses incurred in providing for the abatement, control, or removal of said nuisance. Any expenses incurred shall be entered upon the tax duplicate and become a lien upon the land from the date of entry.

Adopted this 6th day of June, 2018.



Bud Zappitelli, Fiscal Officer

David Ferguson, Trustee



Dave Olmstead, Trustee



Tom Rybski, Trustee

Owner Name	MORRIS GREGORY J	Prop. Class	R - Residential
Site Address	6143 ALICE DR	Land Use	510 - ONE-FAMILY DWLG ON PLATTED L
Legal Descriptions	ALICE DRIVE TAYLOR ESTATES LOT 23	Tax District	220 - PLAIN TOWNSHIP
Mailing Address	PO BOX 758 NEW ALBANY OH 43054	Sch. District	2508 - NEW ALBANY-PLAIN LSD
Transfer Date	09/12/2017	App Nbrhd	05600
Transfer Price	145,000.00	Tax Lein	No
Instrument Type	GW	CAUV Property	No
		Owner Occ. Credit	2017: Yes 2018: Yes
		Homestead Credit	2017: No 2018: No
		Rental Registration	No
		Board of Revision	No
		Zip Code	43081
		Annual Taxes	3,988.80
		Taxes Paid	2,193.84
		Calculated Acreage	.46
		Legal Acreage	.00

	Current Market Value			Taxable Value		
	Land	Improv	Total	Land	Improv	Total
Base	\$64,900	\$81,200	\$146,100	\$22,720	\$28,420	\$51,140
TIF	\$0	\$0	\$0	\$0	\$0	\$0
Exempt	\$0	\$0	\$0	\$0	\$0	\$0
Total	\$64,900	\$81,200	\$146,100	\$22,720	\$28,420	\$51,140
CAUV	\$0					

Building Data

Year Built	1977	Full Baths	1
Finished Area	1092	Half Bath	
Rooms	5	Heat/AC	2
Bedrms	3	Wood Fire	/
Dining Rooms	0	Stories	1

Sketch Legend

- 0 1s FR/PTBPTC 1092 Sq. Ft.
- 1 FRG - 15:FRAME GARAGE 462 Sq. Ft.
- 2 P - 40:CONCRETE PATIO 168 Sq. Ft.
- 3 P - 40:CONCRETE PATIO 110 Sq. Ft.
- 1 WD W/RAIL - WD2:WOOD DECK W/RAIL 190 Sq. Ft.
- 2 MISC - 099:MISC 1 Sq. Ft.
- 3 MISC - 099:MISC 1 Sq. Ft.

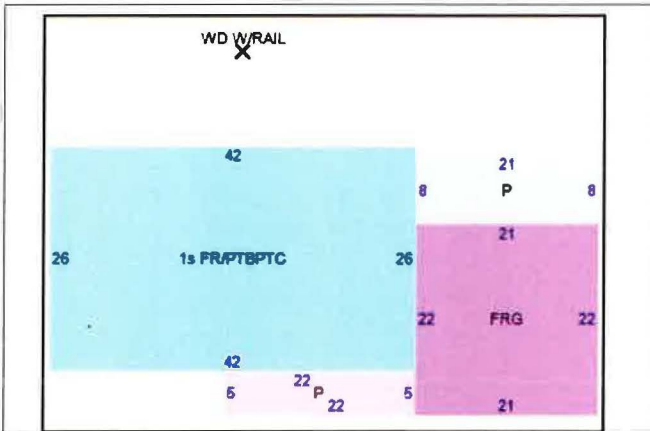

Disclaimer: The information on this web site is prepared from the real property inventory maintained by the Franklin County Auditor's Office. Users of this data are notified that the primary information source should be consulted for verification of the information contained on this site. The county and vendors assume no legal responsibilities for the information contained on this site. Please notify the Franklin County Auditor's Real Estate Division of any discrepancies.



PLAIN TOWNSHIP BOARD OF TRUSTEES
FRANKLIN COUNTY, OHIO

RESOLUTION NO. 180606Z2

A RESOLUTION TO DECLARE A NUISANCE AND ORDER ABATEMENT

WHEREAS Plain Township Parcel Number 220-001012 located at 7650 Morse Road, New Albany, Ohio 43054 is a developed lot with an existing home and the overgrown weeds and vegetation located at 7650 Morse Road constitute a nuisance that is present and ongoing;

THEREFOR BE IT RESOLVED that the Plain Township Board of Trustees hereby orders the documented owner Mahendra Prasanna, of 1293 Terrace Park Drive, Columbus, Ohio 43235, to abate, control, or remove said overgrown weeds and vegetation that are a present and ongoing nuisance and to maintain the yard in a neat and orderly state; *from the rear of the structure to Morse Rd*

BE IT FURTHER RESOLVED that if said overgrown weeds and vegetation are not abated, controlled, or removed, or if provision for its abatement, control or removal is not made within seven (7) days, the Plain Township Board of Trustees shall provide for the abatement, control or removal of said nuisance;

BE IT FURTHER RESOLVED that any expenses incurred by the Plain Township Board of Trustees in providing for the abatement, control, or removal of said nuisance shall be paid out of the township general fund from moneys not otherwise appropriated;

BE IT FURTHER RESOLVED that the Plain Township Board of Trustees shall make a written report to the county auditor identifying the premises and all expenses incurred in providing for the abatement, control, or removal of said nuisance. Any expenses incurred shall be entered upon the tax duplicate and become a lien upon the land from the date of entry.

Adopted this 6th day of June, 2018.



Bud Zappitelli, Fiscal Officer

David Ferguson, Trustee

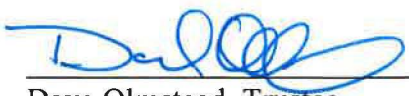

Dave Olmstead, Trustee

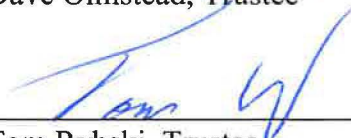

Tom Rybski, Trustee



Owner Name MAHENDRA PRASANNA
BEARAVOLA MADAN MOHAN REDDY,
BHINDWALLAM VENKATESH S

Site Address 7650 MORSE RD

Legal Descriptions MORSE RD
10.0 ACRES

Mailing Address 7650 MORSE RD
NEW ALBANY OH 43054

Transfer Date 04/04/2017
Transfer Price 251,000.00
Instrument Type 051

Prop. Class R - Residential
Land Use 512 - ONE-FAMILY DWLG UNPLT: 10-19.9:
Tax District 220 - PLAIN TOWNSHIP
Sch. District 2508 - NEW ALBANY-PLAIN LSD
App Nbrhd 05600
Tax Lein No
CAUV Property No
Owner Occ. Credit 2017: Yes 2018: Yes
Homestead Credit 2017: Yes 2018: No
Rental Registration No
Board of Revision No
Zip Code 43054
Annual Taxes 8,733.14
Taxes Paid 8,733.14
Calculated Acreage 9.78
Legal Acreage 10.00

	Current Market Value			Taxable Value		
	Land	Improv	Total	Land	Improv	Total
Base	\$207,300	\$133,600	\$340,900	\$72,560	\$46,760	\$119,320
TIF	\$0	\$0	\$0	\$0	\$0	\$0
Exempt	\$0	\$0	\$0	\$0	\$0	\$0
Total	\$207,300	\$133,600	\$340,900	\$72,560	\$46,760	\$119,320
CAUV	\$0					

Building Data

Year Built 1960
Finished Area 1350
Rooms 8
Bedrms 4
Dining Rooms 1
Full Baths 2
Half Bath
Heat/AC 2
Wood Fire 1 / 1
Stories 1

Sketch Legend

- 0 1s FR/B1350 Sq. Ft.
- 1 OP - 13: OPEN FRAME PORCH 88 Sq. Ft.
- 2 FRG - 15: FRAME GARAGE 528 Sq. Ft.
- 3 OP - 13: OPEN FRAME PORCH 180 Sq. Ft.
- 1 POLE BLDG - PB3: FR/MTL POLE BLDG 161107 Sq. Ft.

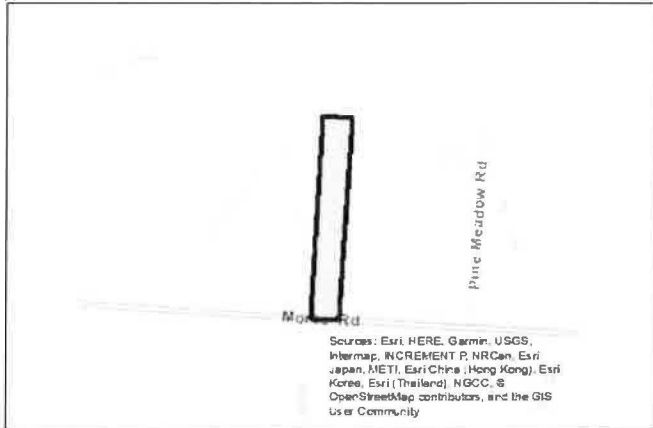
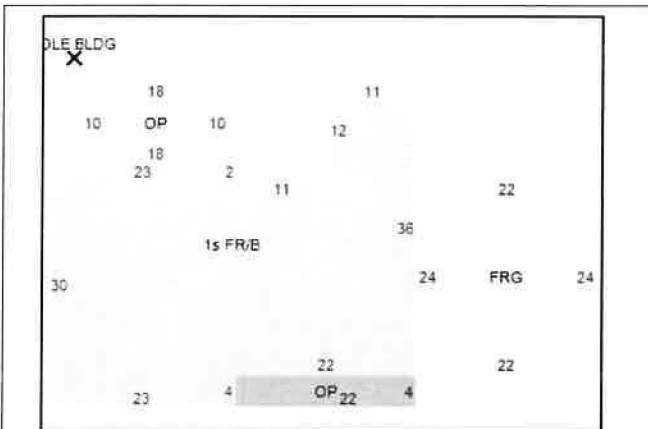

Maintenance Report

6/1/18

Roads

- Checked on a catch basin in Albanyview Drive from resident
 - Will get it fixed in the next couple weeks
- Checked on the condition of Ditch on Bevelhymer Road – No Difference
- Called New Albany about road mowing - Their tractor is down they will get to us when they get it back.
- Picked up roadkill
- Checked intersection lights

Cemetery

- 2 funerals
- Backfilled settled graves & seeded older graves
- Put out veteran flags for veterans day - Michael had to set most of them back up after storms went through Saturday before Memorial Day
- Replaced rope on flag pole
- Mowed and trimmed
- Picked up limbs and debris from windstorms

Pool

- Replaced starburst pump with spare
 - Took bad one to Columbus Electric Works for rebuild.
- Had Don Shoemaker replace the conduit to the starburst pump and hook electric back up to it
- Had Don Shoemaker put in 4 electric outlets in the concession to accommodate new phone and keep the concession to code
- Purchased new microwave for concession
- Had new 'Rules' sign and 'Swim Diaper Required' sign made at Great Impressions
- Purchased three new chemical pumps at Patterson Pools
- Purchased and installed new grade cover for starburst box in the pool floor zero entry
- Touched up painting around the pool building complex buildings best we could when the painting contractor could not get us in before Memorial Day
 - They will be out after pool closes for season to do all of the buildings and slide steps and platform.
- Put out all of the temporary signage around pool parking lot and put out the arrow sign showing where the pool entrance is.
- Put up all of the 20' Funbrellas and cantilever umbrellas, put up tarps on interactive pool, & put up the pull ropes for water feature
- Patched concrete that had chipped off the pull gate posts by concession

Office/Rentals/Fire Department

- Mowed and trimmed
- Replaced Emergency Exit lighting batteries that failed inspection
- Called United refrigeration to check out problem with fire department A/C units
- Pulled weeds in the ivy around entryway

Personnel/Michael Bullard

Since his return from his leave of absence, Michael Bullard has been a huge asset to the township. He went beyond his required duties to make sure the pool and the cemetery were ready for Memorial Day weekend. He has come in early and stayed over when needed. I would like to recommend a pay adjustment. Michael has been here four years and still makes less than what someone starts out at the City of New Albany. I would like to recommend a \$2.00 per hour raise to get the rate to where it is comparable to the pay at New Albany. He has a vast amount of knowledge and a strong work ethic that is hard to find in employees this day. The township has a hard time just getting seasonal help that can even mow, let alone replacing someone who can do an extensive amount of mechanical, skilled, and construction jobs.



2018 Firefighter Line of Duty Deaths in the US: 39

To: Plain Township Board of Trustees
From: Chief Hoovler
Re: Chief's Report
Date: May 11, 2018 to June 1, 2018
Runs 111 EMS, 56 Fires

US Civilian Fire fatalities reported by US news media January 1, 2018 – June 1, 2018: 1251

Ohio Civilian fire fatalities reported by US news media January 1, 2018 – June 1, 2018: 47

May 12	Community CPR class. Testing for new hire.
May 14	CSCC medic student rider.
May 15	Battalion Chief's staff meeting. Prevention education, Marburn Academy, Debbie Barnett, FM Guthrie.
May 16	Prevention education, Marburn Academy student at Station 121 for cooking class, Debbie Barnett, FM Guthrie.
May 17	Prevention education, Marburn Academy student at Station 121 for cooking class, Debbie Barnett, FM Guthrie. OSU Wellness with Dan.
May 18	Prevention education, Safe Kids, Debbie Barnett. OSU Wellness with Dan. Car seat inspections, Debbie Barnett.
May 19	ACLS Class, FFPM Jason Bates. Founders Day, Chief Hoovler, FM Guthrie, Debbie Barnett, 1 Unit.
May 21	CSCC medic student rider. Central Ohio Fire Chief's meeting. Chief Hoovler, Chief Rupp.
May 22	OSU Wellness with Dan. Interviews for new hire.
May 23	CSCC medic rider.
May 24	CSCC medic rider. EMS Training, Mount Carmel, 3 Unit. Interviews for new hire.
May 25	Block Party, 1 Unit.
May 28	CSCC medic student rider, AM. CSCC medic student rider, PM. 7 last day of school block parties, 2 Unit.
May 30	CSCC medic student rider. 3 Unit training at A&F, DC 1 & DC 2.
May 31	CSCC medic student rider. 1 Unit training at A&F, DC 1 & DC 2.
June 1	CSCC medic student rider. Chief Hoovler, Chief Rupp attended reception for retiring Chief Heins of Truro Township.

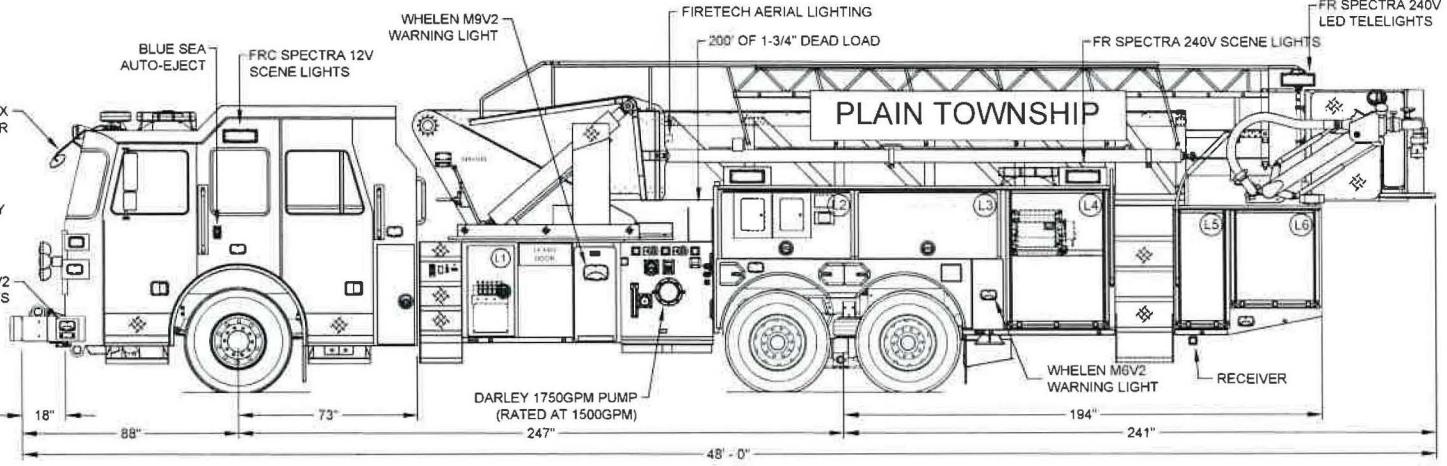
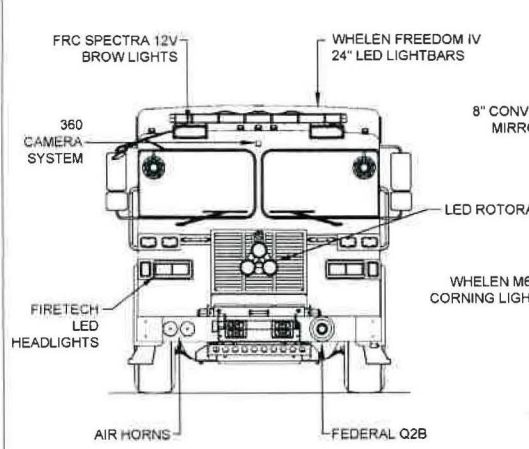
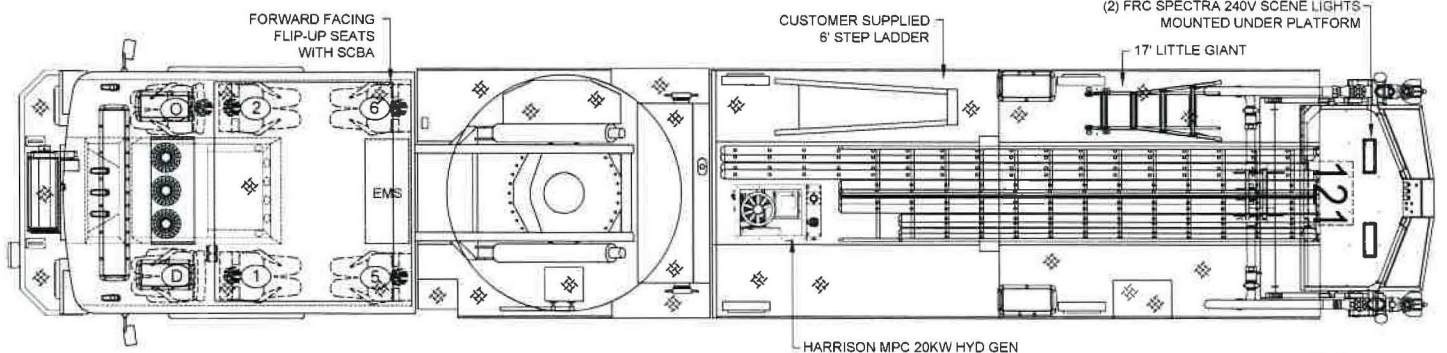
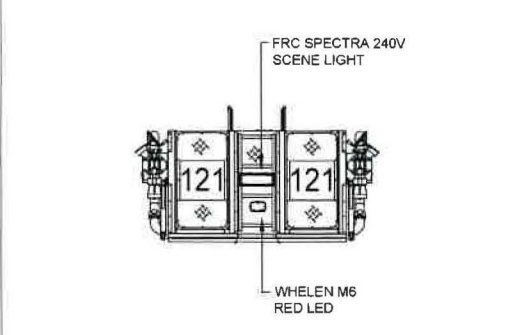
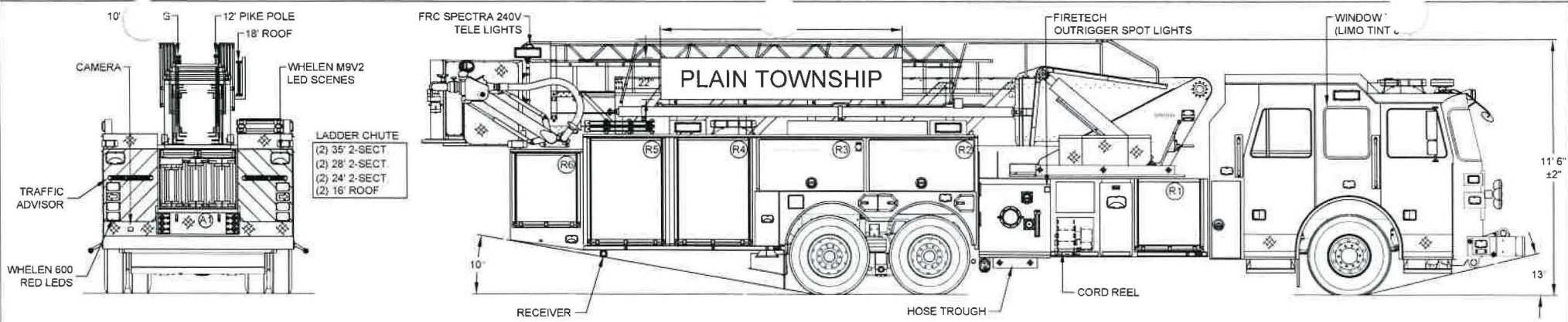

DOOR OPENINGS			COMPARTMENT DIMENSIONS		
COMPT	HEIGHT	WIDTH	HEIGHT	WIDTH	DEPTH
L1	31 1/2	13 1/2	36 1/2	30 1/4	30 1/4
L3	35 3/4	30 7/8	38 1/2	20 5/8	20 1/2
L3	23	50 1/4	27 1/2	56	26 1/2
L4	48 1/2	36 3/4	56 1/2	45 3/4	26 1/2
L5	40 1/2	15 1/8	56 1/2	22	26 1/2
L6	32 1/8	30 7/8	40 1/8	34 3/4	26 1/2

DOOR OPENINGS			COMPARTMENT DIMENSIONS		
COMPT	HEIGHT	WIDTH	HEIGHT	WIDTH	DEPTH
R1	31 1/2	33 1/2	36 1/2	40	27 1/2
R2	23	50 3/4	27 1/2	56	26 1/2
R3	23	50 3/4	27 1/2	56	26 1/2
R4	48 1/2	36 3/4	56 1/2	45 3/4	26 1/2
R5	48 1/2	36 3/4	56 1/2	45 3/4	26 1/2
R6	32 1/8	30 7/8	40 1/8	34 3/4	26 1/2

DOOR OPENINGS		
COMPT	HEIGHT	WIDTH
A1	9 1/8	24 1/2

COMPARTMENT DIMENSIONS		
HEIGHT	WIDTH	DEPTH
9 7/8	26	R6

UPPER WARNING PACKAGE
-WHELEN FREEDOM 24" LT BARS
-WHELEN MCFLED BEACONS
-WHELEN 600 LED

LOWER WARNING PACKAGE
-WHELEN 600 LEADS
-WHELEN TIR3 LEADS

SCENE LIGHTING
-FRC SPECTRA 12V BROW
-WHELEN M9 12V SCENES
-FRC SPECTRA 240V SCENE

DIMENSIONS SHOWN ON THIS DRAWING ARE APPROXIMATE AND ARE SUBJECT TO MINOR DEVIATIONS DURING CONSTRUCTION

IN THE EVENT OF A DISCREPANCY BETWEEN THE SUTPHEN SPECIFICATIONS AND DRAWING, THE SUTPHEN SPECIFICATIONS SHALL PREVAIL

DRAWING IS FOR REFERENCE ONLY. SOME ITEMS PROPOSED MAY NOT BE SHOWN OR NOTED

CUSTOMER APPROVAL

NAME: _____

TITLE: _____

DATE: _____

REV	DESCRIPTION	BY	DATE

DESIGNED BY
J. HOWELL

DATE
05/14/18

MPG FACILITY
DUBLIN

SUTPHEN

PLAIN TOWNSHIP FIRE DEPARTMENT
NEW ALBANY, OH

SPH100 AERIAL PLATFORM
PLAIN TWP OH (2018 SPH-100) DWG

THIS PRINT IS PROVIDED ON A RES/RICTED BASIS AND IS NOT TO BE USED IN ANY WAY DETRIMENTAL TO THE INTERESTS OF SUTPHEN CORPORATION



PURCHASE AGREEMENT
FOR
SUTPHEN FIRE APPARATUS

THIS AGREEMENT, made and entered into this _____ day of _____ June _____, 2018, by and between SUTPHEN CORPORATION of Dublin, Ohio, hereinafter called "SUTPHEN" and the _____ Plain Township _____ of _____ New Albany, Ohio _____ hereinafter called "PURCHASER",

WITNESSETH:

1. **PURCHASE:** Purchaser hereby agrees to buy and Sutphen hereby agrees to sell and furnish to Purchaser the apparatus and equipment according to the Sutphen Proposal attached hereto and made a part hereof, and to deliver the same as hereinafter provided.

2. **PAYMENT:** Purchaser agrees to pay for said apparatus and equipment the total purchase price of One Million Two Hundred Eighty Thousand and Three Hundred and zero cents (\$ 1,280,300.00) payable in full upon delivery.
Note: Price above Includes Trade in deduction of HS 3177 Sutphen Aerial Platform SP-100 -\$60,000.00. If the unit is not traded in at time of delivery this amount for trade in will be included in the final invoice amount for a total selling price \$1,340,300.00

3. **DELIVERY:** The apparatus and equipment being purchased hereunder shall be delivered to Purchaser at 9500 Johnstown Rd. New Albany, OH 43054 within approximately 9-11 Months after the receipt and acceptance of this agreement at Sutphen's office, provided that such delivery date shall be automatically extended for delays due to strikes, failure to obtain materials or other causes beyond Sutphen's control.

4. **SUTPHEN WARRANTIES:** Sutphen warrants the apparatus purchased here under as set forth in the warranty included with bid proposal.

5. TESTING SHORTAGES: The apparatus shall be tested per NFPA #1901 at Sutphen's manufacturing facility. Purchaser agrees that the apparatus and equipment being purchased hereunder will not be driven or used in any manner until it is paid for in full, provided, however, that if there are any minor shortages, Purchaser may withhold a sum equivalent to the retail purchase price of any equipment shortages at the time of delivery and may use the apparatus and equipment during this period.

6. DEFAULT: In the case of any default in payment hereunder or in the payment on any notes, negotiable paper, obligations or other instruments issued by Purchaser, Sutphen may take full possession of the apparatus and equipment or of the piece or pieces upon which default has been made, and any payments that have been made theretofore shall be applied as rent in full for the use of the apparatus and equipment up to the date of taking possession by Sutphen.

7. PURCHASER WARRANTIES: With the signing of this agreement, Purchaser warrants that it has the full power and legal authority to enter into this agreement and guarantees that funds for its purchase are available or in the process of collection.

8. ACCEPTANCE: This agreement shall not be binding until it is signed and approved by an officer of the Sutphen Corporation.

9. TAXES, ETC.: The purchase price provided for herein does not include any federal, state or local sales tax, duties, imposts, revenues, excise or other taxes which may hereafter be imposed by governmental authority or otherwise and which are made applicable to the apparatus or equipment covered by the agreement. In the event that any such taxes are subsequently imposed and become applicable, the purchase price herein shall be increased by the amount of such taxes and such sum shall be immediately paid by Purchaser to Sutphen. To the extent applicable, the prices and deliveries set forth herein are subject to the Defense Production Act.

10. INSURANCE: Sutphen shall provide insurance insuring the apparatus and equipment against loss by fire, theft or collision and insuring against property damage and personal injury through the three (3) day delivery period.

11. GENERAL: This agreement and the Sutphen proposal provided herein take precedence over all previous negotiations, oral or written, and no representations or warranties are applicable except as specifically contained in this agreement or in the Sutphen proposal attached hereto. No alteration, modification, amendment or change of this Agreement shall be binding unless executed in writing by the parties. No waiver of any of the provisions of this Agreement shall be deemed a waiver of any other provision, whether or not similar, nor shall any waiver constitute a continuing waiver.

This Agreement shall be governed and controlled as to interpretation, enforcement, validity, construction, effect and in all other respects by the laws, statutes and decisions of the State of Ohio. Exclusive jurisdiction and venue for any litigation at all related to this Agreement, directly or indirectly, based upon contract, tort, or other theory of law, shall lie in the Franklin County Court of Common Pleas, Columbus, Ohio, and the parties hereto consent and submit to the general jurisdiction of this court. All of the terms and provisions of this Agreement shall be binding upon and inure to the benefit of and be enforceable by Sutphen, Purchaser, their successors and assigns.

IN WITNESS WHEREOF, the parties hereto have caused this agreement to be duly executed and attested by its duly authorized representatives, effective as of the date below when accepted at Sutphen Corporations offices.

SUTPHEN CORPORATION
By _____
Sales Representative

Accepted at office
SUTPHEN CORPORATION
6450 Eiterman Road
Dublin, Ohio 43016

By _____
Title _____
Date _____

PURCHASER
THE _____
Plain Township

By _____

Title _____

By _____

Title _____

By _____

Title _____

Date _____



**FAMILY OWNED
SINCE 1890**

To The:

Plain Township Fire Department
9500 Johnstown Rd.
New Albany, Ohio 43054

Date: May 24, 2018

FOR YOUR REVIEW:

We hereby propose and agree to furnish the following firefighting apparatus upon your acceptance of this proposal:

Reference Ohio State Term Schedule – Contract No. 800257

One (1) Sutphen Aerial Platform SPH-100 with Equipment Package and Communication Package as requested.....	\$1,340,300.00
Trade In of HS 3177 Sutphen Aerial Platform SP-100.....	-\$60,000.00
Total Selling Price with Trade In.....	\$1,280,300.00

The truck will be manufactured completely in accordance to the following proposal and delivered approximately **9-11 Months** after approval of contract, subject to delays from all causes beyond our control. Unless accepted within **30 days** from this date, the right is reserved to withdraw this proposal.

Respectfully submitted by:



Harry Sutphen
Sutphen Corporation
Heritage Fire Equipment

Sutphen Corporation
 PO Box 158 • Amlin, OH 43002-0158
 6450 Eiterman Road • Dublin, OH 43016-8711
Tel 614 889-1005 • Toll Free 800 848-5860 • Fax 614 889-0874
www.sutphen.com • Sutphen@sutphencorp.com

Media Report for PLAIN TWP FD

From 5/11/2018 to 6/1/2018

EMS

	<u>Response DT</u>	<u>Address</u>	<u>Response Type</u>
1.	05/11/2018 09:25	50 VILLAGE HALL RD # , NEW ALBANY	ILLNESS-EMS
2.	05/11/2018 09:58	6145 WITHERSPOON WAY # , COLUMBUS	CHEST PAIN-EMS
3.	05/11/2018 13:39	7400 WEST CAMPUS RD # , NEW ALBANY AETNA INSURANCI	ILLNESS-EMS
4.	05/11/2018 15:17	5187 HARLEM RD # , NEW ALBANY	ILLNESS-EMS
5.	05/11/2018 17:08	6500 NEW ALBANY RD E # , NEW ALBANY DISCOVER CARD F	BEHAVIORAL EMERGENCY-EMS
6.	05/11/2018 18:04	6733 LIBERATION WAY # 509A	ABDOMINAL PAIN-EMS
7.	05/12/2018 10:52	7356 TUMBLEBROOK DR # , NEW ALBANY	ILLNESS-EMS
8.	05/12/2018 13:03	7061 CAMDEN DR # , NEW ALBANY	ILLNESS-EMS
9.	05/12/2018 20:37	13380 JOHNSTOWN-UTICA RD NW # , MONROE TWP	TRAFFIC ACCIDENT HIGH SPEED
10.	05/13/2018 17:07	8164 WOLCOTT LOOP # , NEW ALBANY	ILLNESS-EMS
11.	05/13/2018 21:32	245 E MAIN ST # , NEW ALBANY	CHEST PAIN-EMS
12.	05/14/2018 08:21	7775 SMITHS MILL RD # , NEW ALBANY	ILLNESS-EMS
13.	05/14/2018 11:06	6005 NACOT PL # , NEW ALBANY	DIABETIC PROBLEMS-EMS
14.	05/14/2018 12:18	5220 FOREST DR # , NEW ALBANY	CHEST PAIN-EMS
15.	05/14/2018 15:20	1 CLUB LN # , NEW ALBANY	INJURY-EMS
16.	05/14/2018 16:03	6005 NACOT PL # , NEW ALBANY	DIABETIC PROBLEMS-EMS
17.	05/14/2018 19:06	5462 METZGER CRESCENT # , COLUMBUS	BREATHING PROBLEMS-EMS
18.	05/15/2018 01:07	6823 RIDGE ROCK DR # , COLUMBUS	INJURY-EMS
19.	05/15/2018 02:44	6940 NEW ALBANY RD E # , NEW ALBANY	INJURY-EMS
20.	05/15/2018 14:27	5055 THOMPSON RD # 108	INJURY-EMS
21.	05/15/2018 15:15	7400 WEST CAMPUS RD # , NEW ALBANY AETNA INSURANCI	CHEST PAIN-EMS
22.	05/16/2018 02:16	6915 HARLEM RD # , PLAIN TWP	ILLNESS-EMS
23.	05/16/2018 08:10	6922 JOYSMITH CIR # , NEW ALBANY	INJURY-EMS
24.	05/16/2018 10:17	5950 JOHNSTOWN RD # , NEW ALBANY	CHEST PAIN-EMS
25.	05/16/2018 10:50	5691 THOMPSON RD # 102	CHEST PAIN-EMS
26.	05/16/2018 11:02	6013 TURNWOOD DR # , COLUMBUS	INJURY-EMS
27.	05/16/2018 12:58	153 W MAIN ST # , NEW ALBANY	ILLNESS-EMS
28.	05/16/2018 15:52	245 E MAIN ST # , NEW ALBANY	INJURY-EMS
29.	05/16/2018 16:55	9500 JOHNSTOWN RD # , NEW ALBANY FIRE STATION 121 - F	INJURY-EMS
30.	05/17/2018 02:05	18 PICKETT PL # , NEW ALBANY	PERSONAL ASSIST-EMS
31.	05/17/2018 09:27	6482 CEDAR BROOK DR # , NEW ALBANY	CHEST PAIN-EMS
32.	05/17/2018 13:31	7525 WEST CAMPUS RD # , NEW ALBANY	HEART PROBLEMS-EMS
33.	05/17/2018 16:49	4995 MEADWAY DR # , COLUMBUS	INJURY-EMS
34.	05/17/2018 17:33	6864 BETHANY DR # , COLUMBUS	SEIZURE-EMS
35.	05/17/2018 18:29	6500 NEW ALBANY RD E # , NEW ALBANY	BEHAVIORAL EMERGENCY-EMS
36.	05/18/2018 10:58	6087 SEABISCUIT DR # , COLUMBUS	BREATHING PROBLEMS-EMS
37.	05/18/2018 12:49	7600 FODOR RD # , NEW ALBANY , , , # CLINIC	INJURY-EMS
38.	05/18/2018 13:44	6530 WEST CAMPUS OVAL # , NEW ALBANY , , , # 100	ILLNESS-EMS
39.	05/18/2018 15:20	6530 WEST CAMPUS OVAL # , NEW ALBANY	ILLNESS-EMS
40.	05/19/2018 07:31	9500 JOHNSTOWN RD # , NEW ALBANY FIRE STATION 121 - F	INJURY-EMS
41.	05/19/2018 10:01	7280 MORSE RD # , PLAIN TWP	ABDOMINAL PAIN-EMS
42.	05/19/2018 10:56	4949 E DUBLIN-GRANVILLE RD # , COLUMBUS	BREATHING PROBLEMS-EMS
43.	05/19/2018 15:30	3651 KITZMILLER RD # , JEFFERSON TWP	ABDOMINAL PAIN-EMS
44.	05/20/2018 03:34	245 E MAIN ST # 208 , NEW ALBANY	PERSONAL ASSIST-EMS
45.	05/20/2018 16:57	5344 APPLE RIDGE PL # , COLUMBUS	PERSONAL ASSIST-EMS
46.	05/20/2018 17:41	50 VILLAGE HALL RD # , NEW ALBANY NEW ALBANY POLICE	ABDOMINAL PAIN-EMS
47.	05/20/2018 21:57	5364 THOMPSON RD # , PLAIN TWP	ILLNESS-EMS
48.	05/21/2018 00:52	4995 MEADWAY DR # , COLUMBUS	PERSONAL ASSIST-EMS
49.	05/21/2018 08:09	6928 ROTHWELL ST # , COLUMBUS	INJURY-EMS
50.	05/21/2018 09:41	5555 NEW ALBANY RD E # , COLUMBUS , , , ,	STROKE / CVA-EMS

Media Report for PLAIN TWP FD

From 5/11/2018 to 6/1/2018

EMS

	<u>Response DT</u>	<u>Address</u>	<u>Response Type</u>
51.	05/21/2018 11:11	6310 NEW ALBANY RD W # , COLUMBUS	ABDOMINAL PAIN-EMS
52.	05/21/2018 13:30	7333 SMITHS MILL RD # , NEW ALBANY NEW ALBANY SURGI	HEART PROBLEMS-EMS
53.	05/21/2018 15:59	RED BANK RD, HARLEM TWP / GORSUCH RD, HARLEM TWP	TRAFFIC ACCIDENT-EMS
54.	05/21/2018 17:46	7118 BEVELHYMER RD # , NEW ALBANY	PERSONAL ASSIST-EMS
55.	05/21/2018 18:37	4893 MEADWAY DR # , COLUMBUS	SEIZURE-EMS
56.	05/21/2018 22:54	RAMP JOHNSTOWN RD TO SR 161 EB, NEW ALBANY / JOHN	TRAFFIC ACCIDENT-EMS
57.	05/21/2018 23:10	4995 MEADWAY DR # , COLUMBUS	PERSONAL ASSIST-EMS
58.	05/22/2018 09:12	6500 NEW ALBANY RD E # , NEW ALBANY	ILLNESS-EMS
59.	05/22/2018 09:27	6707 LIBERATION WAY # 407	INJURY-EMS
60.	05/22/2018 09:40	MORSE RD, JEFFERSON TWP / BABBITT RD, JEFFERSON TW	TRAFFIC ACCIDENT HIGH SPEED
61.	05/22/2018 12:31	7795 WALTON PKWY # , NEW ALBANY	CHEST PAIN-EMS
62.	05/22/2018 14:22	177 N HIGH ST # , NEW ALBANY	INJURY-EMS
63.	05/22/2018 15:37	4995 MEADWAY DR # , COLUMBUS	ILLNESS-EMS
64.	05/22/2018 18:31	HAVENS CORNERS RD, JEFFERSON TWP / N WAGGONER RI	TRAFFIC ACCIDENT-EMS
65.	05/23/2018 10:10	1191 VENETIAN WAY # , GAHANNA	INJURY-EMS
66.	05/23/2018 18:20	9500 JOHNSTOWN RD # , NEW ALBANY FIRE STATION 121 - F	BREATHING PROBLEMS-EMS
67.	05/23/2018 22:03	50 VILLAGE HALL RD # , NEW ALBANY NEW ALBANY POLICE	INJURY-EMS
68.	05/24/2018 09:35	7333 SMITHS MILL RD # , NEW ALBANY NEW ALBANY SURGI	ILLNESS-EMS
69.	05/24/2018 10:38	MORSE RD, JEFFERSON TWP / REYNOLDSBURG-NEW ALBA	TRAFFIC ACCIDENT-EMS
70.	05/24/2018 16:31	6912 KEESEE CIR # , NEW ALBANY	OVERDOSE-EMS
71.	05/25/2018 11:12	6922 ROTHWELL ST # , COLUMBUS	INJURY-EMS
72.	05/25/2018 12:58	150 E GRANVILLE ST # , NEW ALBANY COLUMBUS JEWISH D	INJURY-EMS
73.	05/25/2018 13:34	7600 FODOR RD # , NEW ALBANY NEW ALBANY HIGH SCHOC	INJURY-EMS
74.	05/25/2018 14:51	6500 NEW ALBANY RD E # , NEW ALBANY	ILLNESS-EMS
75.	05/26/2018 09:50	7118 BEVELHYMER RD # , NEW ALBANY	PERSONAL ASSIST-EMS
76.	05/26/2018 15:11	4585 N REYNOLDSBURG NEW ALBANY RD # , NEW ALBANY	INJURY-EMS
77.	05/26/2018 19:09	5006 JOHNSTOWN RD # , NEW ALBANY	BEHAVIORAL EMERGENCY-EMS
78.	05/27/2018 09:07	5705 TRADITIONS DR # , NEW ALBANY	INJURY-EMS
79.	05/27/2018 10:57	6693 ESTATE VIEW DR N # , JEFFERSON TWP	INJURY-EMS
80.	05/27/2018 18:44	5661 COURAGE DR # , COLUMBUS	ILLNESS-EMS
81.	05/28/2018 04:07	7118 BEVELHYMER RD # , NEW ALBANY	PERSONAL ASSIST-EMS
82.	05/28/2018 11:01	1185 JACKSON HOLE DR # , JEFFERSON TWP	STROKE / CVA-EMS
83.	05/28/2018 12:43	7955 HAVENS RD # , JEFFERSON TWP	ILLNESS-EMS
84.	05/28/2018 14:17	7650 SWICKARD WOODS BLVD # , NEW ALBANY PLAIN TOWI	INJURY-EMS
85.	05/28/2018 16:51	NEW ALBANY RD W, COLUMBUS / CENTRAL COLLEGE RD, C	TRAFFIC ACCIDENT-EMS
86.	05/28/2018 17:56	5809 WARNER MEADOWS DR # , COLUMBUS	BARIATRIC EMERGENCY-EMS
87.	05/28/2018 18:15	6087 SEABISCUIT DR # , COLUMBUS	BREATHING PROBLEMS-EMS
88.	05/28/2018 20:20	1502 STEWART PL # , JEFFERSON TWP	ILLNESS-EMS
89.	05/28/2018 22:47	NEW ALBANY-CONDIT RD, NEW ALBANY / SNIDER LOOP, NE	ILLNESS-EMS
90.	05/29/2018 02:53	7692 BRANDON RD # , NEW ALBANY	UNKNOWN EMERGENCY-EMS
91.	05/29/2018 03:04	E DUBLIN-GRANVILLE RD, COLUMBUS / LITTLE TURTLE WAY	TRAFFIC ACCIDENT HIGH SPEED
92.	05/29/2018 12:57	1201 RIVA RIDGE CT # , GAHANNA	INJURY-EMS
93.	05/29/2018 16:19	7219 ALMA TERRACE DR # , COLUMBUS	BREATHING PROBLEMS-EMS
94.	05/30/2018 10:10	5684 PROVISION ST # , COLUMBUS	CHEST PAIN-EMS
95.	05/30/2018 12:08	10659 JOHNSTOWN RD # , PLAIN TWP CROSS POINT CHRIS	INJURY-EMS
96.	05/30/2018 13:08	9725 JOHNSTOWN RD # , NEW ALBANY	ILLNESS-EMS
97.	05/30/2018 14:26	153 W MAIN ST # , NEW ALBANY	HEMORRHAGE-EMS
98.	05/30/2018 16:08	973 EAST JOHNSTOWN RD # , GAHANNA	UNCONSCIOUS PERSON-EMS
99.	05/31/2018 12:00	1 CLUB LN # , NEW ALBANY	ILLNESS-EMS
100.	05/31/2018 12:07	6842 NEWROCK DR # , COLUMBUS	UNCONSCIOUS PERSON-EMS

Media Report for PLAIN TWP FD

From 5/11/2018 to 6/1/2018

EMS

	<u>Response DT</u>	<u>Address</u>	<u>Response Type</u>
101.	05/31/2018 13:23	1045 BEECHER CROSSING N # B	BREATHING PROBLEMS-EMS
102.	05/31/2018 13:57	6883 JERSEY DR # , NEW ALBANY	ILLNESS-EMS
103.	05/31/2018 14:54	6405 DARLING RD # , JEFFERSON TWP	SEIZURE-EMS
104.	05/31/2018 17:33	323 RITA CT # , GAHANNA	HEMORRHAGE-EMS
105.	05/31/2018 17:50	4723 WENHAM PARK # , COLUMBUS	CHEST PAIN-EMS
106.	05/31/2018 18:29	6995 HAVENS CORNERS RD # , JEFFERSON TWP	TRAFFIC ACCIDENT-EMS
107.	05/31/2018 20:18	LEE RD, PLAIN TWP / E WALNUT ST, PLAIN TWP	TRAFFIC ACCIDENT-EMS
108.	06/01/2018 08:51	7185 UPPER ALBANY DR # , COLUMBUS	BITE ANIMAL / HUMAN-EMS
109.	06/01/2018 08:55	7400 WEST CAMPUS RD # , NEW ALBANY AETNA INSURANCI	DIABETIC PROBLEMS-EMS
110.	06/01/2018 14:15	4010 PRINCE GEORGE LN # , NEW ALBANY	BEHAVIORAL EMERGENCY-EMS
111.	06/01/2018 21:13	4224 AVIS RD # , PLAIN TWP	INJURY-EMS

Media Report for PLAIN TWP FD

From 5/11/2018 to 6/1/2018

FIRE

	<u>Response DT</u>	<u>Address</u>	<u>Response Type</u>
1.	05/11/2018 04:03	245 E MAIN ST # , NEW ALBANY	ALARM HIGH LIFE / VALUE-FIRE
2.	05/11/2018 08:53	7165 PLEASANT COLONY CIR # 68	ALARM RESIDENTIAL FIRE-FIRE
3.	05/11/2018 15:46	8287 MARWITHE PL # , NEW ALBANY	FIRE RESIDENTIAL STRUCTURE-
4.	05/12/2018 11:27	5933 BABBITT RD # , PLAIN TWP	INVESTIGATION/SERVICE RUN-F
5.	05/12/2018 11:56	45 KESWICK WOODS # , NEW ALBANY	INVESTIGATION/SERVICE RUN-F
6.	05/12/2018 17:03	775 E JOHNSTOWN RD # , GAHANNA SUNRISE ASSISTED LIV	ALARM HIGH LIFE / VALUE-FIRE
7.	05/12/2018 22:10	6969 DORAN DR # , NEW ALBANY	WORKING FIRE RESIDENTIAL-FI
8.	05/13/2018 05:52	5220 FOREST DR # , NEW ALBANY	ALARM COMMERCIAL FIRE-FIRE
9.	05/13/2018 06:30	9880 JOHNSTOWN RD # , NEW ALBANY TURKEY HILL	FIRE MULCH-FIRE
10.	05/13/2018 15:22	4604 GOODHEART CT # , NEW ALBANY	ALARM RESIDENTIAL FIRE-FIRE
11.	05/14/2018 16:48	260 MARKET ST # , NEW ALBANY	ALARM COMMERCIAL FIRE-FIRE
12.	05/14/2018 20:49	312 JAMES RD # , GAHANNA	WORKING FIRE COMMERCIAL-FI
13.	05/15/2018 04:51	245 E MAIN ST # , NEW ALBANY	ALARM COMMERCIAL FIRE-FIRE
14.	05/15/2018 12:32	6707 LIBERATION WAY # , COLUMBUS	ALARM HIGH LIFE / VALUE-FIRE
15.	05/15/2018 12:45	12895 WORTHINGTON RD # , JERSEY TWP LIBERTY JEEP	ALARM COMMERCIAL FIRE-FIRE
16.	05/15/2018 14:22	SMITHS MILL RD, NEW ALBANY / JOHNSTOWN RD, NEW ALB	FIRE MULCH-FIRE
17.	05/15/2018 14:40	5500 HARLEM RD # , HARLEM TWP	FIRE RESIDENTIAL STRUCTURE-
18.	05/15/2018 14:55	6539 SUMMIT RD	ALARM COMMERCIAL FIRE-FIRE
19.	05/16/2018 12:46	10 HIGHGROVE # , NEW ALBANY , , ,	ALARM RESIDENTIAL FIRE-FIRE
20.	05/16/2018 17:07	775 E JOHNSTOWN RD # , GAHANNA SUNRISE ASSISTED LIV	ALARM HIGH LIFE / VALUE-FIRE
21.	05/16/2018 20:11	5760 THOMPSON RD # , NEW ALBANY	INVESTIGATION/SERVICE RUN-F
22.	05/17/2018 13:19	238 N MAIN ST # , JOHNSTOWN	FIRE RESIDENTIAL STRUCTURE-
23.	05/17/2018 14:10	6925 KINDLER DR # , NEW ALBANY	INVESTIGATION/SERVICE RUN-F
24.	05/17/2018 15:56	1341 AMBERLEA DR W # , GAHANNA	ALARM RESIDENTIAL FIRE-FIRE
25.	05/17/2018 19:58	4075 QUENTIN BLVD # 101, COLUMBUS	ALARM HIGH LIFE / VALUE-FIRE
26.	05/18/2018 16:42	114 BELLEBROOKE DR # , PATASKALA	FIRE RESIDENTIAL STRUCTURE-
27.	05/19/2018 15:25	6390 HAVENS CORNERS RD # , JEFFERSON TWP	FIRE RESIDENTIAL STRUCTURE-
28.	05/19/2018 16:10	6030 WALNUT ST # , PLAIN TWP	INVESTIGATION/SERVICE RUN-F
29.	05/19/2018 16:38	75 KESWICK DR # , NEW ALBANY	CO ALARMS / CHECK-FIRE
30.	05/19/2018 20:45	4934 STRAND RD # , COLUMBUS	RESCUE ELEVATOR-FIRE
31.	05/19/2018 21:36	175 E MAIN ST # , NEW ALBANY	ALARM COMMERCIAL FIRE-FIRE
32.	05/20/2018 16:00	75 KESWICK DR # , NEW ALBANY	CO ALARMS / CHECK-FIRE
33.	05/21/2018 07:32	6197 WALTON BRECK WAY # , COLUMBUS	ALARM WATERFLOW-FIRE
34.	05/21/2018 20:14	730 CLOTTS RD # , GAHANNA	ALARM HIGH LIFE / VALUE-FIRE
35.	05/22/2018 08:28	65 S WILLIAMS ST # , JOHNSTOWN CHIMES TERRACE	FIRE HIGH LIFE / VALUE STRUCT
36.	05/22/2018 20:31	5435 MORSE RD # 166 THREE CREEKS SENIOR LIVING	ALARM HIGH LIFE / VALUE-FIRE
37.	05/23/2018 13:14	223 CRESTVIEW DR # , JOHNSTOWN	FIRE RESIDENTIAL STRUCTURE-
38.	05/24/2018 00:21	5220 FOREST DR # , NEW ALBANY	ALARM COMMERCIAL FIRE-FIRE
39.	05/24/2018 05:56	12591 WORTHINGTON RD # , JERSEY TWP ALL TAILS R WAG	ALARM COMMERCIAL FIRE-FIRE
40.	05/24/2018 17:26	6630 TAYLOR RD # , JEFFERSON TWP JESS HOWARD ELECT	ALARM COMMERCIAL FIRE-FIRE
41.	05/24/2018 20:26	5691 THOMPSON RD # , COLUMBUS	ALARM RESIDENTIAL FIRE-FIRE
42.	05/26/2018 00:36	5220 FOREST DR # , NEW ALBANY	ALARM COMMERCIAL FIRE-FIRE
43.	05/26/2018 07:27	150 W MAIN ST # , NEW ALBANY PHILIP HEIT FOR HEALTHY I	INVESTIGATION/SERVICE RUN-F
44.	05/26/2018 17:55	7591 BRANDON RD # , NEW ALBANY	CO ALARMS / CHECK-FIRE
45.	05/27/2018 09:13	245 E MAIN ST # , NEW ALBANY	ALARM COMMERCIAL FIRE-FIRE
46.	05/28/2018 16:53	7477 NEW ALBANY LINKS DR # , NEW ALBANY	ALARM RESIDENTIAL FIRE-FIRE
47.	05/28/2018 17:45	6912 KEESEE CIR # , NEW ALBANY	LOCK OUT-FIRE
48.	05/29/2018 09:11	5977 TREVEN WAY # , COLUMBUS	NATURAL GAS LEAK-FIRE
49.	05/30/2018 11:04	7275 SOUTHFIELD RD # , NEW ALBANY	INVESTIGATION/SERVICE RUN-F
50.	05/30/2018 12:44	9880 JOHNSTOWN RD # , NEW ALBANY TURKEY HILL	FIRE COMMERCIAL STRUCTURE

Media Report for PLAIN TWP FD

From 5/11/2018 to 6/1/2018

FIRE

	<u>Response DT</u>	<u>Address</u>	<u>Response Type</u>
51.	05/30/2018 14:02	LEE RD, PLAIN TWP / E WALNUT ST, PLAIN TWP	INVESTIGATION/SERVICE RUN-F
52.	05/30/2018 21:27	7275 SOUTHFIELD RD # , NEW ALBANY	INVESTIGATION/SERVICE RUN-F
53.	05/31/2018 11:02	153 W MAIN ST # , NEW ALBANY	LOCK OUT-FIRE
54.	05/31/2018 13:32	5050 N HAMILTON RD # , COLUMBUS	ALARM COMMERCIAL FIRE-FIRE
55.	06/01/2018 12:31	5700 ROCKY RIDGE LANDINGS DR # , COLUMBUS	FOREIGN ODOR-FIRE
56.	06/01/2018 21:35	163 E PRATT ST # D, JOHNSTOWN	FIRE COMMERCIAL STRUCTURE

**PLAIN TOWNSHIP BOARD OF TRUSTEES
FRANKLIN COUNTY, OHIO**

RESOLUTION NO. 180606F2

A RESOLUTION TO PAY OHIO HEALTH LIFELINK

Be it resolved to pay Ohio Health Lifelink \$3400.00 for a PHTLS Class out of fund 28-A-05C EMS (Other - Training). \$3275.00 will be covered by the EMS grant money.

Adopted this 6th day of June 2018



Bud Zappitelli, Fiscal Officer

David Ferguson, Trustee



Dave Olmstead, Trustee



Tom Rybski, Trustee

PLAIN TOWNSHIP FIRE DEPARTMENT
COMBINED EMS and FIRE RUN STATISTICS

MONTHLY TOTALS

	1998	1999	2000	2001	2002	2003	2004	2005	2006	2007	2008	2009	2010	2011	2012	2013	2014	2015	2016	2017	2018
JANUARY									142	129	128	135	152	175	153	161	234	184	177	222	232
FEBRUARY									115	156	143	118	167	174	166	156	161	209	203	184	198
MARCH									113	131	120	148	126	155	143	157	174	173	201	215	175
APRIL									114	138	134	129	151	136	184	137	168	218	196	201	210
MAY									129	154	114	143	106	137	174	158	174	199	212	225	250
JUNE									138	133	150	146	173	168	208	150	159	210	195	236	
JULY									130	134	138	112	157	186	204	186	196	190	203	226	
AUGUST									147	144	139	148	172	181	192	184	163	209	243	253	
SEPTEMBER									123	137	183	132	166	179	152	162	193	195	221	224	
OCTOBER									166	154	168	163	155	162	176	160	203	198	233	212	
NOVEMBER									132	147	126	107	148	162	168	197	218	200	215	212	
DECEMBER									135	133	159	147	161	166	197	188	220	219	227	226	
TOTAL	1137	1149	1258	1355	1215	1435	1660	1755	1584	1690	1702	1628	1834	1981	2117	1996	2263	2404	2526	2636	1065
% CHANGE	+16.5	+1.1	+9.5	+7.7	-10.3	+18.1	+15.7	+5.7	-9.7	+6.7	+0.7	-4.3	+12.7	+8.0	+6.9	-5.7	+13.4	+6.2	+5.1	+4.4	

average of 5.09% INCREASE per year

RUNNING TOTALS

	1998	1999	2000	2001	2002	2003	2004	2005	2006	2007	2008	2009	2010	2011	2012	2013	2014	2015	2016	2017	2018
JANUARY									142	129	128	135	152	175	153	161	234	184	177	222	232
FEBRUARY									257	285	271	253	319	349	319	317	395	393	380	406	430
MARCH									370	416	391	401	445	504	462	474	569	566	581	621	605
APRIL									484	554	525	530	596	640	646	611	737	784	777	822	815
MAY									613	708	639	673	702	777	820	769	911	983	989	1047	1065
JUNE									751	841	789	819	875	945	1028	919	1064	1193	1184	1283	
JULY									881	975	927	931	1032	1131	1232	1105	1266	1383	1387	1509	
AUGUST									1028	1119	1066	1079	1204	1312	1424	1289	1429	1592	1630	1762	
SEPTEMBER									1151	1256	1249	121	1370	1491	1576	1451	1622	1787	1851	1986	
OCTOBER									1317	1410	1417	1374	1525	1653	1752	1611	1825	1985	2084	2198	
NOVEMBER									1449	1557	1543	1481	1673	1815	1920	1808	2043	2185	2299	2410	
DECEMBER									1584	1690	1702	1628	1834	1981	2117	1996	2263	2404	2526	2636	

PLAIN TOWNSHIP FIRE DEPARTMENT

EMS RUN STATISTICS

MONTHLY TOTALS

	1998	1999	2000	2001	2002	2003	2004	2005	2006	2007	2008	2009	2010	2011	2012	2013	2014	2015	2016	2017	2018
JANUARY	42	65	67	78	38	65	81	62	80	81	73	75	92	121	100	112	117	121	114	151	138
FEBRUARY	36	68	60	75	57	60	63	69	74	85	89	70	110	112	116	111	99	115	129	112	137
MARCH	46	59	50	75	56	59	70	76	65	81	77	87	85	110	99	102	104	102	141	144	113
APRIL	47	42	66	69	56	63	76	76	68	99	75	93	93	86	122	84	112	135	133	133	126
MAY	71	58	50	65	66	71	84	88	87	99	71	96	63	102	106	110	115	117	147	155	155
JUNE	71	61	55	73	61	65	82	103	84	78	81	92	114	114	138	97	95	137	127	172	
JULY	63	72	62	76	71	88	74	79	79	86	87	75	98	116	118	116	117	129	133	144	
AUGUST	55	49	62	88	62	88	76	93	86	93	87	103	104	124	132	120	112	143	163	155	
SEPTEMBER	65	64	62	60	54	90	75	92	77	91	107	84	111	125	104	101	134	137	162	158	
OCTOBER	62	54	70	70	78	77	100	95	104	107	117	109	89	108	116	104	127	133	164	149	
NOVEMBER	50	59	61	75	58	69	83	95	92	93	82	58	87	88	100	122	131	120	140	142	
DECEMBER	79	43	74	43	76	78	99	97	86	91	96	91	102	105	137	122	150	155	139	150	
TOTAL	687	694	739	838	733	873	963	1025	982	1084	1042	1033	1148	1311	1388	1301	1413	1544	1692	1765	669
% CHANGE	+8.5	+1	+6.5	+13.4	-12.5	+19.1	+10.3	+6.4	-4.2	+10.4	-3.9	-0.9	+11.3	+14.2	+5.9	-6.3	+8.6	+9.3	+9.6	+4.3	

average of 5.26% INCREASE per year

RUNNING TOTALS

	1998	1999	2000	2001	2002	2003	2004	2005	2006	2007	2008	2009	2010	2011	2012	2013	2014	2015	2016	2017	2018
JANUARY	42	65	67	78	38	65	81	62	80	81	73	75	92	119	100	112	117	121	114	151	138
FEBRUARY	78	133	127	153	95	125	144	131	154	166	162	145	202	233	216	223	216	236	243	263	275
MARCH	124	192	177	228	151	184	214	207	219	247	239	232	287	343	315	325	320	338	384	407	388
APRIL	171	234	243	297	207	247	290	283	287	346	314	325	380	429	437	409	432	473	517	540	514
MAY	242	292	293	362	273	318	374	371	374	445	385	421	443	531	543	519	547	590	664	695	669
JUNE	313	353	348	435	334	383	456	474	458	523	466	513	557	645	681	616	642	727	791	867	
JULY	376	425	410	511	405	471	530	553	537	609	553	588	655	761	799	732	759	856	924	1011	
AUGUST	431	474	472	599	467	559	606	646	623	702	640	691	759	885	931	852	871	999	1087	1166	
SEPTEMBER	496	538	534	659	521	649	681	738	700	793	747	775	870	1010	1035	953	1005	1136	1249	1324	
OCTOBER	558	592	604	729	599	726	781	833	804	900	864	884	959	1118	1151	1057	1132	1269	1413	1473	
NOVEMBER	608	651	665	795	657	795	864	928	896	993	946	942	1046	1206	1251	1179	1263	1389	1553	1615	
DECEMBER	687	694	739	838	733	873	963	1025	982	1084	1042	1033	1148	1311	1388	1301	1413	1544	1692	1765	

PLAIN TOWNSHIP FIRE DEPARTMENT

FIRE/RESCUE RUN STATISTICS

MONTHLY TOTALS

	1998	1999	2000	2001	2002	2003	2004	2005	2006	2007	2008	2009	2010	2011	2012	2013	2014	2015	2016	2017	2018
JANUARY	32	38	58	60	45	48	45	71	62	48	55	60	60	54	53	49	117	63	63	71	94
FEBRUARY	19	33	38	43	35	45	52	54	41	71	54	48	57	62	50	45	62	94	74	72	61
MARCH	35	34	41	50	36	40	60	58	48	50	43	61	41	45	44	55	64	71	60	71	62
APRIL	31	31	40	42	26	46	37	53	46	39	59	36	58	50	62	53	56	83	63	68	84
MAY	49	34	53	36	35	53	64	61	42	55	43	47	43	35	68	48	59	82	65	70	84
JUNE	37	40	46	38	30	38	49	65	54	55	69	54	59	54	70	53	64	73	68	64	
JULY	34	42	37	40	49	55	48	69	51	48	51	37	59	70	86	70	79	61	70	82	
AUGUST	40	35	33	51	56	62	53	80	61	51	52	45	68	57	60	64	51	66	80	98	
SEPTEMBER	48	41	33	43	43	44	45	46	46	46	76	48	55	54	48	61	59	58	59	66	
OCTOBER	38	42	53	37	42	47	48	44	62	47	51	54	66	54	60	56	76	65	69	63	
NOVEMBER	41	49	35	40	42	48	36	53	40	54	44	49	61	74	68	75	87	80	75	70	
DECEMBER	46	39	52	37	43	36	160	76	49	42	63	56	59	61	60	66	70	64	88	76	
TOTAL	450	458	519	517	482	562	697	730	602	606	660	595	686	670	729	695	844	860	834	871	385
% CHANGE	+31.2	+1.8	+13.3	-0.4	-6.8	+16.6	+20.0	+4.7	-17.5	+0.6	+8.9	-9.8	+15.3	-2.3	+8.8	-4.7	+21.4	+1.9	-3.0	+4.4	

average of 4.77% INCREASE per year

RUNNING TOTALS

	1998	1999	2000	2001	2002	2003	2004	2005	2006	2007	2008	2009	2010	2011	2012	2013	2014	2015	2016	2017	2018
JANUARY	32	38	58	60	45	48	45	71	62	48	55	60	60	54	53	49	117	63	63	71	94
FEBRUARY	51	71	96	103	80	93	97	125	103	119	109	108	117	116	103	94	179	157	137	143	155
MARCH	86	105	137	153	116	133	157	183	151	169	152	169	158	161	147	149	243	228	197	214	217
APRIL	117	136	177	195	142	179	194	236	197	208	211	205	216	211	209	202	299	311	260	282	301
MAY	166	170	230	231	177	232	258	297	239	263	254	252	259	246	277	250	358	393	325	352	385
JUNE	203	210	276	269	207	270	307	362	293	318	323	306	318	300	347	303	422	466	393	416	
JULY	237	252	313	309	256	325	355	431	344	366	374	343	377	370	433	373	501	527	463	498	
AUGUST	277	287	346	360	312	387	408	511	405	417	426	388	445	427	493	437	552	593	543	596	
SEPTEMBER	325	328	379	403	355	431	453	557	451	463	502	436	500	481	541	498	611	651	602	662	
OCTOBER	363	370	432	440	397	478	501	601	513	510	553	490	566	535	601	554	687	716	671	725	
NOVEMBER	404	419	467	480	439	526	537	654	553	564	597	539	627	609	669	629	774	796	746	795	
DECEMBER	450	458	519	517	482	562	697	730	602	606	660	595	686	670	729	695	844	860	834	871	

**+PLAIN TOWNSHIP BOARD OF TRUSTEES
FRANKLIN COUNTY, OHIO**

RESOLUTION NO. 180606F3

A RESOLUTION TO PAY PHYSIO CONTROL

Be it resolved to pay Physio Control \$2,930.76 for annual maintenance out of fund 28-A-05F EMS (Routine Repair).

Adopted this 6th day of June 6, 2018,



Bud Zappitelli, Fiscal Officer

David Ferguson, Trustee



Dave Olmstead, Trustee



Tom Rybski, Trustee

